

# Pièces de rechange Spare parts list

**K100\*\*02\*\***

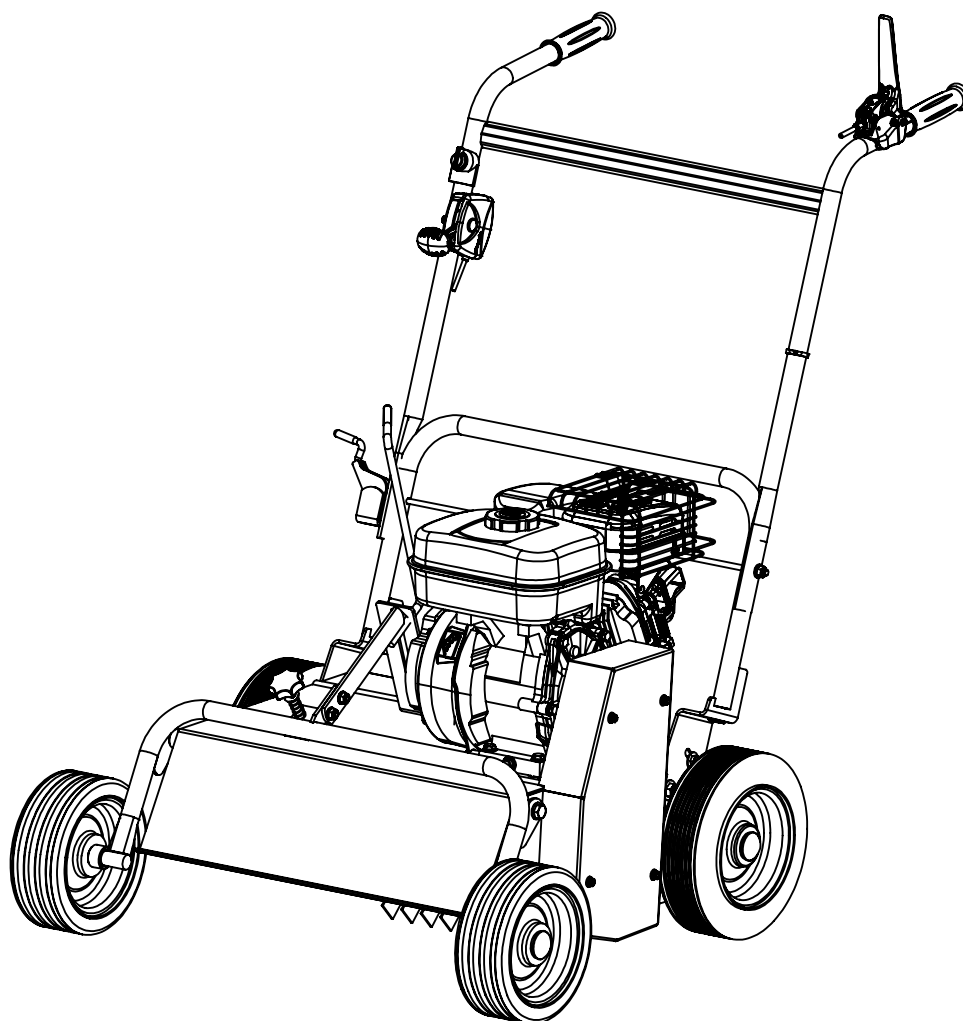

**SCARIFICATEUR  
SCARIFIER**

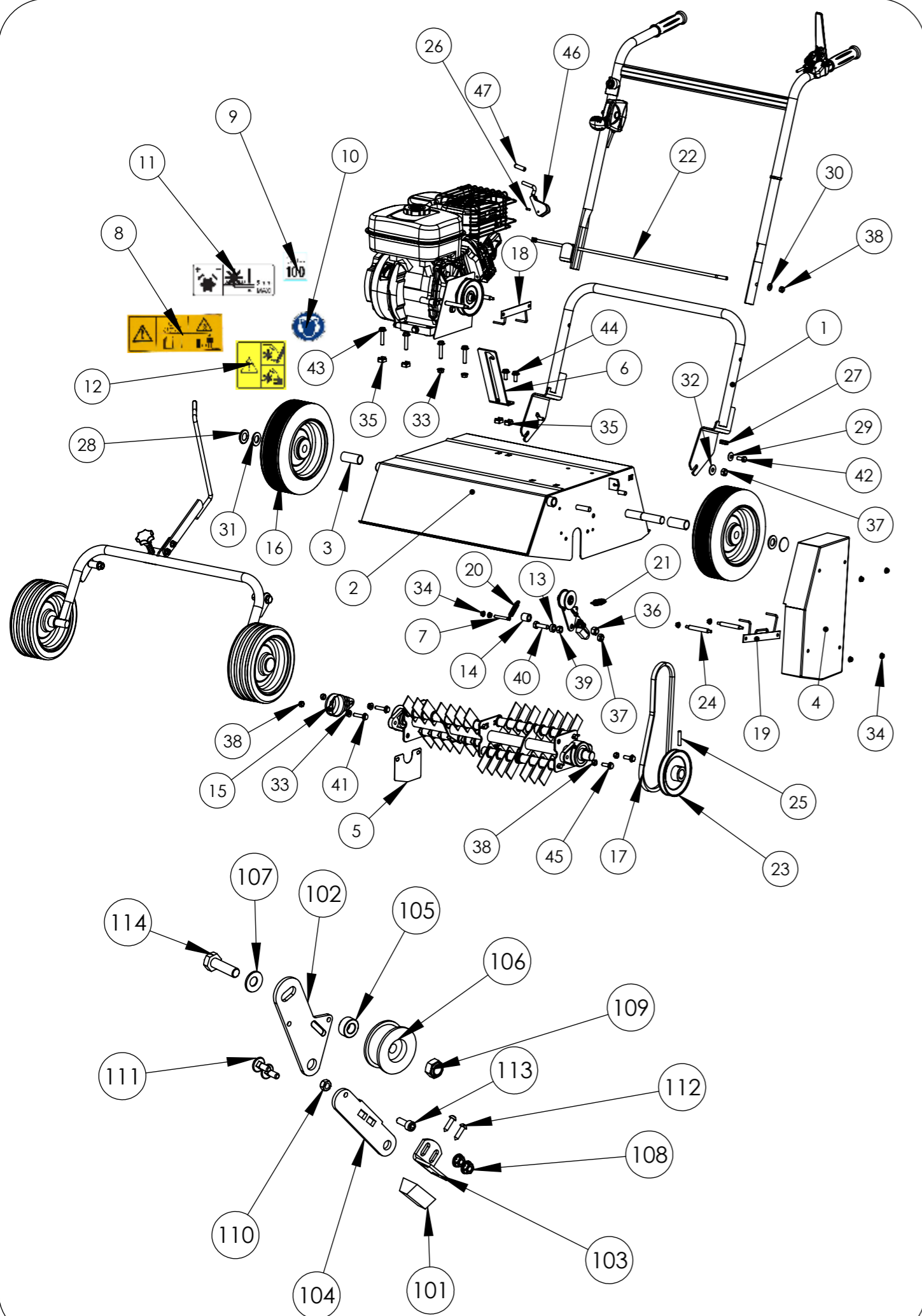

Rep N°	Ref.	Désignation	Description	Qté
1	KI02021101	SUPPORT MANCHERON SCARIF 50 GRIS CLAIR	LIGHT GRAY HANDLEBAR BASE	1
1	KI02021201	SUPPORT MANCHERON SCARIF 50 GRIS FONCE	DARK GRAY HANDLEBAR BASE	1
1	KI02021601	SUPPORT MANCHERON SCARIF 50 NOIR	BLACK HANDLEBAR BASE	1
2	KI02020601	CARTER SCARIF 50 ROUGE RAL 3002	RED CARTER SCARIF 50 RAL3002	1
2	KI02020701	CARTER SCARIF 50 ROUGE RAL 3000	RED CARTER SCARIF 50 RAL3000	1
2	KI02023601	CARTER SCARIF 50 BLEU	BLUE CARTER SCARIF 50	1
2	KI02022101	CARTER SCARIF 50 VERT	GREEN CARTER SCARIF 50	1
2	KI02022601	CARTER SCARIF 50 ORANGE	ORANGE CARTER SCARIF 50	1
3	KI02020202	ENTRETOISE ROUE ARR SCARIF 50	ROUND SPACER FOR REAR WHEEL	2
4	KI02011601	CAPOT COURROIE SCARIF NOIR	BLACK BELT CARTER SCARIF	1
5	KI02010402	PROTECTION CARTER SCARIF ZN NOIR	BLACK PROTECTIVE CARTER	1
6	KI02010204	SELECTEUR HAUTEUR SCARIF ZN	WORK LEVEL SELECTION TOOL	1
7	KC04010022	VIS BIELETTE EMBRAYAGE	CLUTCH SCREW	1
8	K503000029-	AUTOCOLLANT PRECAUTION D'EMPLOI	STICKER "CAUTION OF USE"	1
9	K503000019-	AUTOCOLLANT 100 D.B.A.	STICKER 100 D.B.A.	1
10	K503000012-	AUTOCOLLANT CASQUE	STICKER "EARMUFF"	1
11	K503000008-	AUTOCOLLANT REGLAGE HAUTEUR DE COUPE	STICKER "HEIGHT ADJUSTMENT"	1
12	K503000007-	AUTOCOLLANT DANGER SECTIONNEMENT	STICKER "DANGER"	1
13	K341000010	ENTRETOISE PLASTIQUE FREIN SCARIF	ROUND SPACER FOR BRAKES	1
14	K341000009	ENTRETOISE LEVIER EMBRAYAGE SCARIF	ROUND SPACER	1
15	K340000044	CACHE PALIER	BEARING COVER	1
16	K309000006	ROUE 250 X 80	WHELL 250 X 80	2
17	K306030028	COURROIE LA33	BELT LA33	1
18	K305030009	PLAQUE DEBRAYAGE SUPERIEURE SCARIF	UPPER DECLUTCHING PLATE	1
19	K305030006	PLAQUE DE DEBRAYAGE INFERIEURE	LOWER DECLUTCHING PLATE	1
20	K305010011	RESSORT RAPPEL LEVIER EMBRAYAGE	SPRING	1
21	K305010006	RESSORT DE RAPPEL	SPRING	1
22	K305000018	TRINGLE BLOCAGE MANCHERON SCARIF 50	HANDLEBAR LOCKING AXLE	1
23	K303020012	POULIE ROTOR SCARIF 50	TRANSMISSION PULLEY SCARIF 50	1
24	K302010022	AXE EPAULE FIXATION CAPOT	CARTER INSTALLATION AXLE	2
25	K301020005	GOUPILLE ROULEE 8 X 40	COTTER PIN 8x40 HBK	1
26	K301020003	GOUPILLE HBK 4 X 16	COTTER PIN 4x16 HBK	1
27	K301000005	PASSE FIL	WIRE PROTECT	1
28	K300702001	ENJOLIVEUR Ø20	TRIM STOPPER	2
29	K300430802	RONDELLE CONTACT LARGE M8	LARGE WASHER M8	2
30	K300430801	RONDELLE CONTACT M8	WASHER M8	1
31	K300402001	RONDELLE PLATE 20 X 36 X 3	PLATE WASHER 20 X 36 X 3	2
32	K300401002	RONDELLE PLATE 27 x 10.25 x 2 ZN	WASHER 27 x 10.25 x 2 ZN	2
33	K300260801	ECROU H M8 EMB CR	NUT H M8 NOTCHED SHOULDER	4
34	K300260601	ECROU H M6 Z EMB CR	NUT H M6 Z NOTCHED SHOULDER	8
35	K300230802	ECROU ' RAPID' DE 8 C4808 B	NUT RAPID M8 C 4808B	6
36	K300211201	ECROU FREIN M12	NUT BRAKE M10	1
37	K300211001	ECROU FREIN M10	BLOCKING NUT M10	3
38	K300210801	ECROU FREIN H M8	BLOCKING NUT M8	5
39	K300201001	ECROU HU M10	NUT HU M10	1
40	K300011010	VIS HM 10 x 35	SCREW HM 10 x 35	1
41	K300010831	Vis HM 8x35 EMB CR	SCREW HM 8x35 notched shoulder	2
42	K300010815	VIS H M8 x 20 ZN	SCREW HM 8 x 20	2
43	K300010803	VIS H EMB CR 8 x 40	SCREW H NOTCHED SHOULDER 8 X 40	4
44	K300010802	VIS EMB CR 8 x 20	SCREW H NOTCHED SHOULDER 8 X 20	2
45	K300010801	VIS H EMB CR 8 x 25	SCREW H NOTCHED SHOULDER 8 X 25	2
46	KI02010209	LEVIER VERROUILLAGE MANCHERON	HANDLEBAR LOCKING LEVER	1
47	0341000125	EMBOUT TYPE A-Ø 7.5 x 35	CAP Ø 7.5 x 35	1
Rep N°	Ref.	Désignation	Description	Qté
101	KI04010016	FREIN ROTOR SCARIF	ROTOR'S BRAKE	1
102	KI02010208	LEVIER EMBRAYAGE SCARIF ZN	CLUTCH LEVER	1
103	KI02010207	EQUERRE FIXATION COURROIE DE FREIN PLIEE	FIXING BRAKE CARPENTER'S SQUARE	1
104	KI02010206	LEVIER FIXATION FREIN SCARIF TARAUDE	FIXING BRAKE PLATE	1
105	K341000013	ENTRETOISE 10.5 x 20 x 9	ROUND SPACER 10.5 x 20 x 9	1
106	K306010001	GALET EMBRAYAGE	CLUTCH PULLEY	1
107	K300431001	RONDELLE CONTACT M 10	WASHER M10	1
108	K300260601	ECROU H M6 Z EMB CR	NUT H M6 Z NOTCHED SHOULDER	2
109	K300211001	ECROU FREIN M10	BLOCKING NUT M10	1
110	K300200602	ECROU HU M6	NUT HU M6	1
111	K300080601	VIS TRCC 6 x 16	SCREW TRCC 6 x 16	2
112	K300070401	VIS TOLE TCL POZ 4.2 x 15.9 ZN	SCREW POZI DRIVE 4.2 x 15.9	2
113	K300020603	VIS CHC 6 x 16 ZN	SCREW CHC 6 X 16 ZN	1
114	K300011010	VIS HM 10 x 35	SCREW HM 10 x 35	1

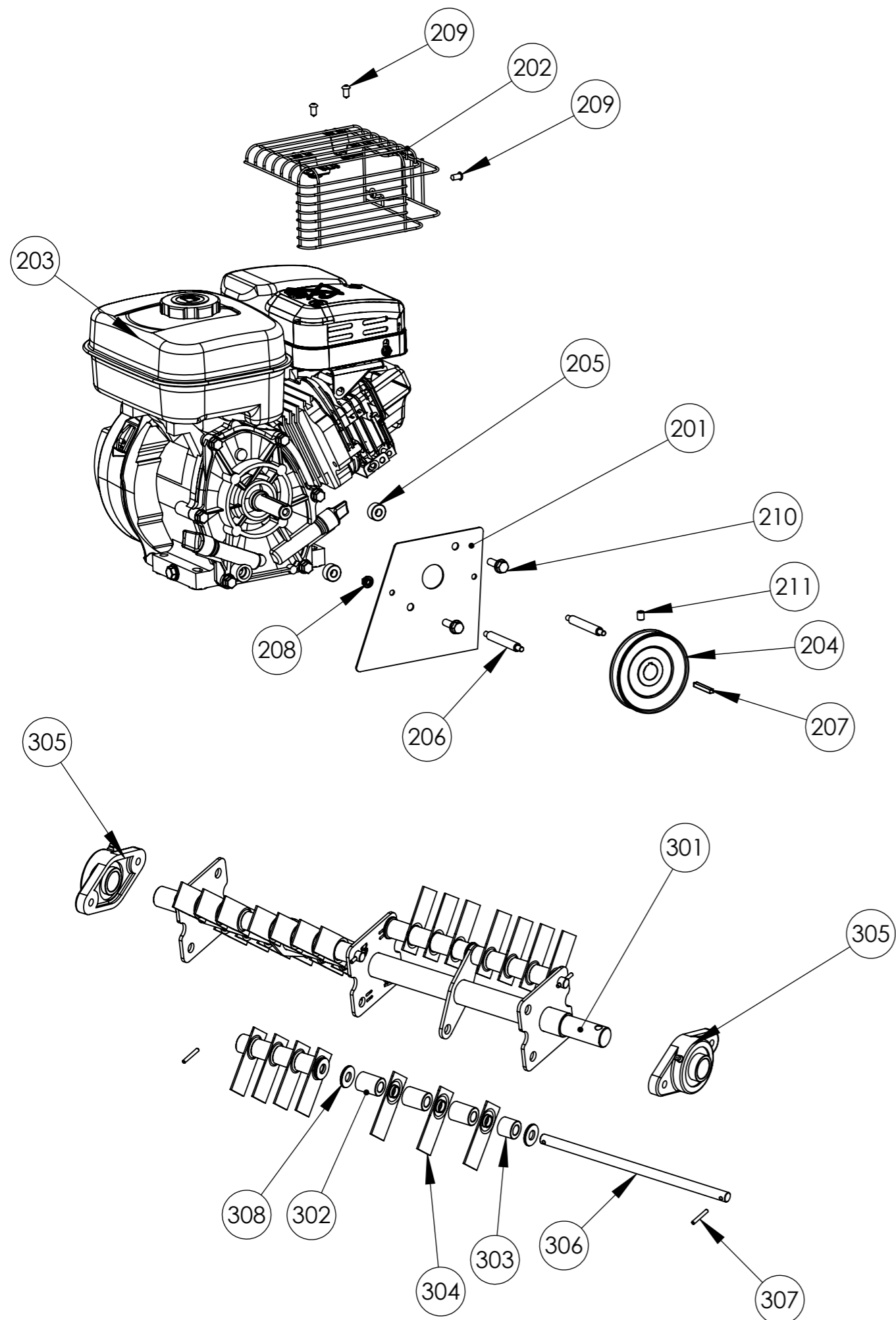

Rep N°	Ref.	Désignation	Description	Qté
201	KI02011602	TOLE PROTECTION POULIE MOTEUR SCARIF NOIR	CARTER FOR ENGINE'S PULLEY	1
202	K330030201	GRILLE ECHAPPEMENT EP	EXHAUST GRILL EP	1
202	K330010206	GRILLE ECHAP GX120/GX160	EXHAUST GRILL GX120/GX160	1
203	0330021025	BRIGGS 950 SERIES HORIZONTAL		1
203	K330010106	HONDA GX 160 *	HONDA GX 160 *	1
203	K330030105	MOTEUR SUBARU EP 17 *	SUBARU EP 17 ENGINE*	1
203	K330030104	MOTEUR SUBARU EP 16 *	SUBARU EP 16 ENGINE *	1
204	K303020010	POULIE MOTEUR SCARIF	ENGINE'S PULLEY	1
205	K302020034	ENTRETOISE TOLE PROTECTION SCARIF	ROUND SPACER	2
206	K302010022	AXE EPAULE FIXATION CAPOT	CARTER INSTALLATION AXLE	2
207	K301040002	CLAVETTE B.DROIT 4.76 x 4.76 x 37	KEY 4.76 X 4.76 X 37	1
208	K300260601	ECROU H M6 Z EMB CR	NUT H M6 Z NOTCHED SHOULDER	2
209	K300070601	VIS TOLE TCL POZ 6.3 x 13 ZN	SCREW TCL POZ 6.3 X 13 ZN	3
210	K300060506	VIS TH EMB CR5/16 LG25 8.8UNF	SCREW TH5/16X25 NOTCHED SHOULD	2
211	K300040802	VIS STHC 8 X 10 BOUT CUVETTE	SCREW STHC 8 X 10	1

\* Le service après vente moteur : S'adresser au réseau motoriste concerné.

\* Obvious guarantee : Contact the motorist sales network

Rep N°	Ref.	Désignation	Description	Qté
301	KI02020203	ROTOR RENFORCE SCARIF 50	ROTOR AXLE	1
302	K340000096	ENTRETOISE PLASTIQU.30.1	ROUND SPACER 30.1	24
303	K340000095	ENTRETOISE PLASTIQU.20.4	ROUND SPACER 20.4	8
304	K320020028	COUTEAU EMBOUTI	KNIFE	28
305	K306010012	PALIER FONTE DIAM=25	SELF - ALIGNING BEARING UNIT	2
306	K302010025	AXE FIXATION COUTEAUX MOBILES SCARIF 50	KNIVES AXLE	4
307	K301090009	GOUPILLE HBK 4 X 30	ROLLED COTTER 4 x 30	8
308	0300401201	RONDELLE PLATE M 12X27X2.5 Z	PLATE WASHER M 12X27X2.5 Z	12

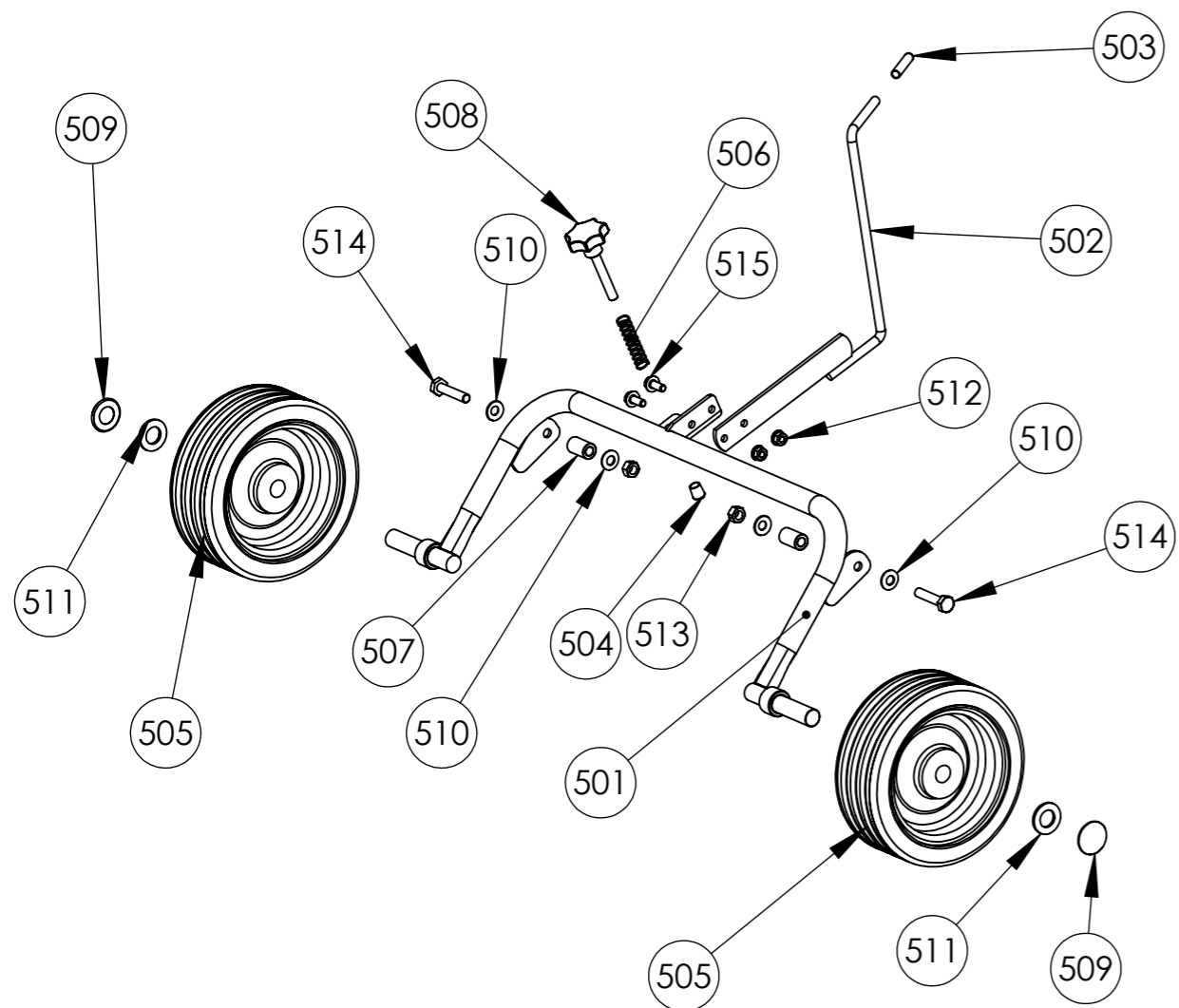
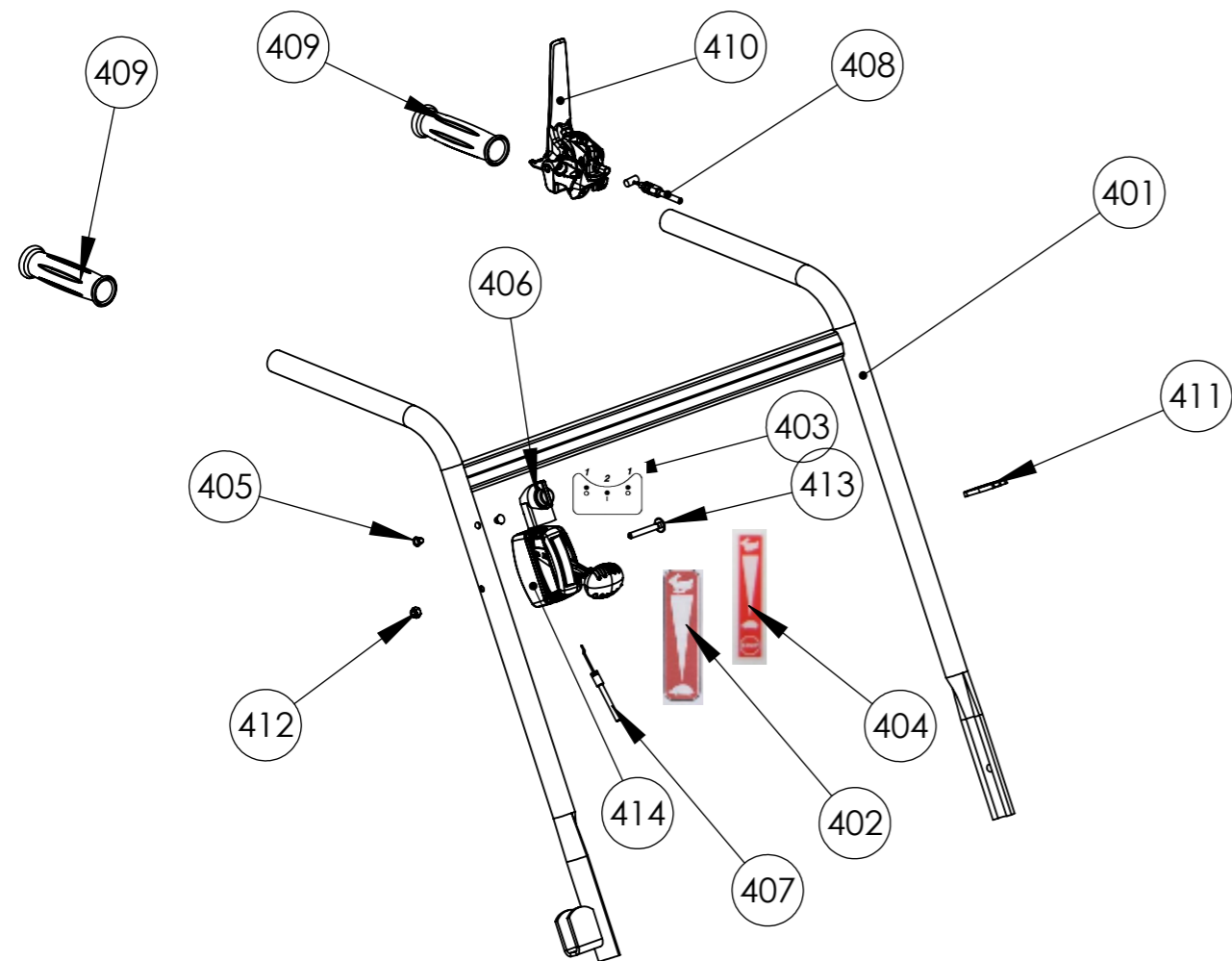

Rep N°	Ref.	Désignation	Description	Qté
401	KI02021103	MANCHERON SCARIF 50 GRIS CLAIR	LIGHT GRAY HANDLEBAR SCARIF 50	1
401	KI02021203	MANCHERON SCARIF 50 GRIS FONCE	DARK GRAY HANDLEBAR SCARIF 50	1
401	KI02021603	MANCHERON SCARIF 50 NOIR	BLACK HANDLEBAR SCARIF 50	1
402	K503000037-	ETIQU. GAZ (SS STOP SS START)	STICKER THROTTLE	1
403	K503000032-	AUTOCOLLANT SWITCH	SWITCH STICKER	1
404	K503000031-	AUTOCOLLANT ACCELERATEUR STOP SANS STARTER	STICKER "ENGINE SPEED VARIATION" WITHOUT STARTER	1
405	K341000011	OBTURATEUR 10 x 7 x 6.5	CAP 10 X 7 X 6.5	2
406	K330010203	SWITCH MOTEUR HONDA	SWITCH HONDA ENGINE	1
407	K308040011	CABLE COMMANDE DES GAZ	THROTTLE CABLE	1
408	K308020009	CABLE EMBR ROTOR SCARIF	CLUTCH CABLE	1
409	K307020005	POIGNEE CAOUTCHOUC DIAM 25	GRIP	2
410	K307010018	LEVIER EMBRAYAGE	CLUTCH LEVER	1
411	K301060001	COLLIER PLASTIQUE	COLLAR	4
411	K301060002	COLLIER PLASTIQUE NOIR	BLACK COLLAR	4
412	K300210601	ECROU FREIN H M6	BLOCKING NUT M6	1
413	K300080603	BOULON TRCC 6 x 45	SCREW TRCC 6 X 45	1
414	K307020010	POIGNEE GAZ	THROTTLE LEVER	1

Rep N°	Ref.	Désignation	Description	Qté
501	KI02021602	TRAIN AVANT SCARIF NOIR	BLACK FRONT AXLE SCARIF	1
501	KI02021202	TRAIN AVANT SCARIF GRIS FONCE	DARK GRAY FRONT AXLE SCARIF	1
501	KI02021102	TRAIN AVANT SCARIF GRIS CLAIR	LIGHT GRAY FRONT AXLE SCARIF	1
502	KI02010202	LEVIER DE RELEVAGE SCARIF SOUDE	LIFT HANDLE	1
503	K341000012	EMBOU PLASTIQUE DIAMETRE 9 x 50	END PIECE LENGTH : 50	1
504	K341000006	EMBOU ROND ENVELOPPANT	PLASTIC CAP	1
505	K309000005	ROUE 210 X 75	WHEEL 210 X 75	2
506	K305020005	RESSORT POIGNEE REGLAGE HAUT	SPRING	1
507	K302020017	ENTRETOISE ARTICULATION	ROUND SPACER	2
508	K300801001	MOLETTE REGLAGE HAUT. M10	HEIGHT LEVEL ADJUSTMENT	1
509	K300702001	ENJOLIVEUR Ø20	TRIM STOPPER	2
510	K300431001	RONDELLE CONTACT M 10	WASHER M10	4
511	K300402001	RONDELLE PLATE 20 X 36 X 3	PLATE WASHER 20 X 36 X 3	2
512	K300260801	ECROU H M8 EMB CR	NUT H M8 NOTCHED SHOULDER	2
513	K300201001	ECROU HU M10	NUT HU M10	2
514	K300011012	VIS TH 10 x 50 ZN	SCREW TH 10 X 50 ZN	2
515	K300010802	VIS EMB CR 8 x 20	SCREW H NOTCHED SHOULDER 8 X 20	2